

# Dial Test Indicators

## SERIES 513 — Horizontal Type

DIAL TEST INDICATORS



513-404E



513-464E



513-414E



513-401E



513-405E



513-424E  
513-414E  
513-466E



513-404E  
513-464E



513-415E



513-426E



513-405E  
513-465E



513-425E



513-401E



513-409

### FEATURES

- Performs easy and accurate measurement of narrow or recessed areas, plus inside and outside diameters that dial indicators cannot access.
- No-clutch structure for automatic reversal of measuring direction.
- Resistant to water and dust thanks to the one-piece bezel and "crystal" design with O-ring.
- The glare-free flat crystal face has a scratch-resistant coating.
- High-sensitivity and quick-response because of jeweled bearings.
- A carbide contact point is provided as standard.

### Dimensions

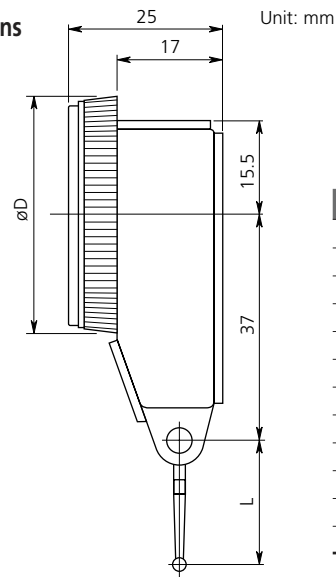

Order No.	D	L
513-424E	39	22.3
513-414E	39	36.8
513-466E	28	22.3
513-404E	39	20.9
513-464E	28	20.9
513-415E	39	44.5
513-426E	39	22.3
513-405E	39	14.7
513-465E	28	14.7
513-425E	39	14.7
513-401E	39	12.8
513-409	39	14.7



High Precision Type



Doubled Scale Spacing



Long Contact Point



Revolution Counter



Compact Type



Dustproof



Jeweled













































Anti-Magnetic



Water resistance

## SPECIFICATIONS

Metric								
Graduation	Range	Order No. Basic unit	Order No. Basic set	Order No. Full set	Dial reading	Accuracy	Measuring force	Remarks
0.01mm	0.5mm	513-424E	513-424A	513-424T	0-25-0	5µm	0.3N or less	  
		513-414E	513-414A	513-414T	0-25-0	10µm	0.2N or less	   
		513-466E	—	—	0-25-0	5µm	0.3N or less	   
	0.8mm	513-404E	513-404A	513-404T	0-40-0	8µm	0.3N or less	 
		513-464E	—	—	0-40-0	8µm	0.3N or less	  
	1mm	513-415E	513-415A	513-415T	0-50-0	10µm	0.2N or less	  
0.002mm	0.2mm	513-405E	513-405A	513-405T	0-100-0	3µm	0.3N or less	 
		513-465E	—	—	0-100-0	3µm	0.3N or less	  
	0.6mm	513-425E	513-425A	—	0-100-0	6µm	0.4N or less	  
0.001mm	0.14mm	513-401E	—	—	0-70-0	3µm	0.3N or less	  

Inch								
Graduation	Range	Order No. Basic unit	Order No. Basic set	Order No. Full set	Dial reading	Accuracy	Measuring force	Remarks
.0005"	.03"	513-402	—	513-402T	0-15-0	±.0005"	0.3N or less	 
		513-412	—	513-412T	0-15-0	±.0005"	0.2N or less	  
		513-462	—	—	0-15-0	±.0005"	0.3N or less	  
.0001"	.008"	513-403	—	513-403T	0-4-0	±.0001"	0.3N or less	 
		513-463	—	—	0-4-0	±.0001"	0.3N or less	  

Metric/Inch								
Graduation	Range	Order No. Basic unit	Order No. Basic set	Order No. Full set	Dial reading	Accuracy	Measuring force	Remarks
0.002mm/.0001"	0.2mm/.0075"	513-409	—	513-409T	0-10-0/0-38-0	3µm	0.3N or less	 

Inch/Metric								
Graduation	Range	Order No. Basic unit	Order No. Basic set	Order No. Full set	Dial reading	Accuracy	Measuring force	Remarks
.0005"/0.01mm	.03"/0.7mm	513-406	—	513-406T	0-15-0/0-35-0	±.0005"	0.3N or less	 

## Set Configurations

### Metric (Metric/Inch)

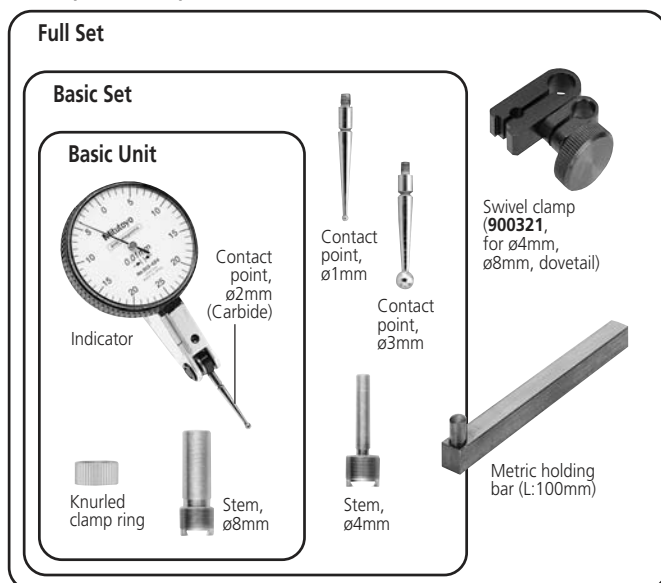

### Inch (Inch/Metric)

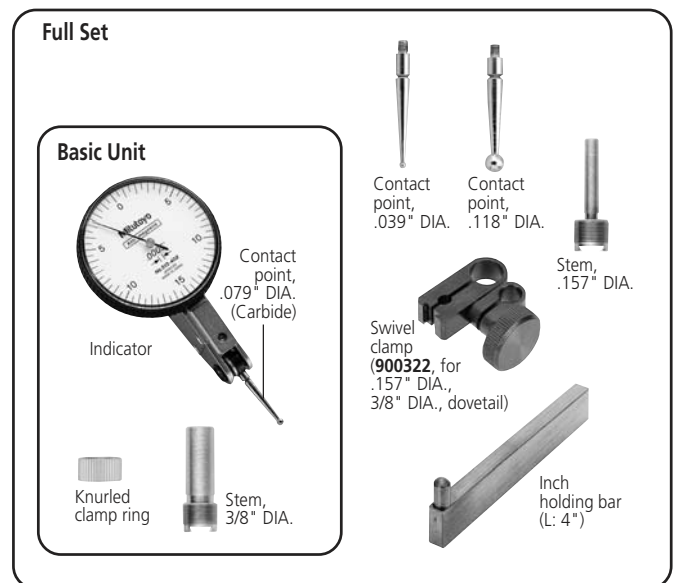

 High Precision Type	 Doubled Scale Spacing	 Long Contact Point	 Revolution Counter
 Compact Type	 Dustproof	 Jeweled	 Anti-Magnetic
			 Water resistance

DIAL TEST INDICATORS

