

119 x 119 x 38mm

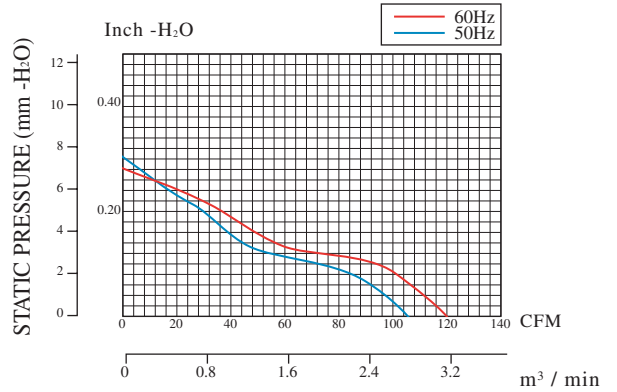
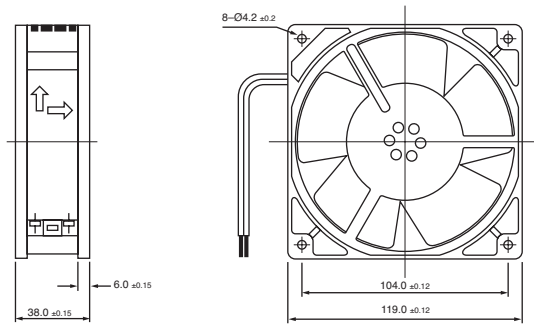

Frame Type: Aluminum painted & Plastic UL94V-0
Impeller: Metal 100°C~120°C

Model	Part No. Terminal Leadwire	Bearing System	Rated Voltage	Freq	Current	Input Power	Speed	Air Flow	Static Pressure	Noise Level	Weight
(型號)	(端子/出線)	(培林)	(V)	(Hz)	(A)	(W)	(rpm)	(CFM)	(mm-H ₂ O)	(dB-A)	(g)
HPE-1238HA1-M	1238HA1-MSAT(L) 1238HA1-MBAT(L)	Sleeve Ball	110/120	50/60	0.21/0.28	24/22	2700/3000	106/120	0.29/0.27	46/50	600
HPE-1238HA2-M	1238HA2-MSAT(L) 1238HA2-MBAT(L)	Sleeve Ball	220/240	50/60	0.07/0.09	22/21	2700/3000	106/120	0.29/0.27	46/50	600
HPE-1238MA1-M	1238MA1-MSAT(L) 1238MA1-MBAT(L)	Sleeve Ball	110/120	50/60	0.21/0.28	22/20	2000/2200	79/82	0.13/0.11	39/41	600
HPE-1238MA2-M	1238MA2-MSAT(L) 1238MA2-MBAT(L)	Sleeve Ball	220/240	50/60	0.09/0.12	20/19	2000/2200	79/82	0.13/0.11	39/41	600

Specifications subject to change without notice.
 以上參考數據，如有變更恕不另行通知。