

# Panasonic

## Installation Guide

### Network Camera

Model No. **WV-ST165/WV-ST162**  
**WV-ST165E/WV-ST162E**

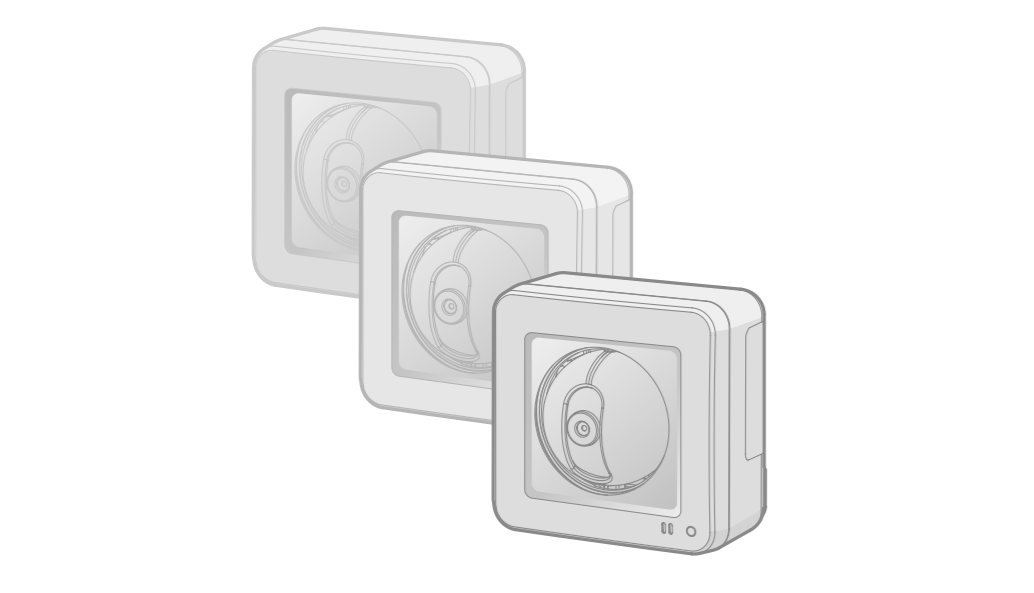

<b>For U.S. and Canada:</b>	<b>For Europe and other countries:</b>
<b>Panasonic System Networks Company of America, Unit of Panasonic Corporation of North America</b> www.panasonic.com/business/For customer support, call 1.800.528.6747. Three Panasonic Way, Secaucus, New Jersey 07094 U.S.A.	<b>Panasonic Corporation</b> http://panasonic.net Importer's name and address to follow EU rules: Panasonic Testing Centre Panasonic Marketing Europe GmbH Winsberging 15, 22525 Hamburg FR,Germany www.panasonic.ca
<b>Panasonic Canada Inc.</b> 5770 Ambler Drive, Mississauga, Ontario, L4W 2T3 Canada (905)624-5010 www.panasonic.ca	

© Panasonic System Networks Co., Ltd. 2011

**PGQX10982A** Cs1011-0

<b>WARNING:</b>
<ul style="list-style-type: none"><li>To prevent fire or electric shock hazard, do not expose this apparatus to rain or moisture.</li> <li>To prevent injury, this apparatus must be securely attached to the floor/wall/ceiling in accordance with the installation instructions.</li> <li>The installation shall be carried out in accordance with all applicable installation rules.</li> <li>The connections should comply with local electrical code.</li></ul>
<p><b>For U.S.A</b></p> <p>This product contains a CR Coin Cell Lithium Battery which contains Perchlorate Material - special handling may apply. See www.dtsc.ca.gov/hazardouswaste/perchlorate/</p> <p><b>For U.S. and Canada:</b> WV-ST165/WV-ST162 For Europe and other countries: WV-ST165E/WV-ST162E</p> <p>UL listed model No. WV-ST165/WV-ST162</p> <p><b>For Canada</b></p> <p>This Class A digital apparatus complies with Canadian ICES-003.</p> <p><b>For U.S.A</b></p> <p>NOTE: This equipment has been tested and found to comply with the limits for a Class A digital device, pursuant to Part 15 of the FCC Rules. These limits are designed to provide reasonable protection against harmful interference when the equipment is operated in a commercial environment. This equipment generates, uses, and can radiate radio frequency energy and, if not installed and used in accordance with the instruction manual, may cause harmful interference to radio communications. Operation of this equipment in a residential area is likely to cause harmful interference in which case the user will be required to correct the interference at his own expense.</p> <p>FCC Caution: To assure continued compliance, (example - use only shielded interface cables when connecting to computer or peripheral devices). Any changes or modifications not expressly approved by the party responsible for compliance could void the user's authority to operate this equipment.</p> <p><b>For U.S.A</b></p> <p>The model number and serial number of this product may be found on the surface of the unit. You should note the model number and serial number of this unit in the space provided and retain this book as a permanent record of your purchase to aid identification in the event of theft.</p> <p>Model No. _____ Serial No. _____</p>

For Europe We declare under our sole responsibility that the product to which this declaration relates is in conformity with the standard or other normative document following the provisions of Directive 2004/108/EC.

Wir erklären in alleiniger Verantwortung, daß das Produkt, auf das sich diese Erklärung bezieht, mit der folgenden Norm oder normativen Dokument übereinstimmt. Gemäß den Bestimmungen der Richtlinie 2004/108/EC.

Nous déclarons sous notre propre responsabilité que le produit auquel se réfère la présente déclaration est conforme à la norme spécifiée ou à tout autre document normatif conformément aux dispositions de la directive 2004/108/CE.

Nosotros declaramos bajo nuestra única responsabilidad que el producto a que hace referencia esta declaración está conforme con la norma u otro documento normativo siguiendo las estipulaciones de la directiva 2004/108/CE.

Noi dichiariamo sotto nostra esclusiva responsabilità che il prodotto a cui si riferisce la presente dichiarazione risulta conforme al seguente standard o altro documento normativo conforme alle disposizioni della direttiva 2004/108/CE.

Vi verklaar als enige aansprakelijke, dat het product waarop deze verklaring betrekking heeft, voldoet aan de volgende norm of ander normatief document, overeenkomstig de bepalingen van Richtlijn 2004/108/EC.

Vi erklærer os eneansvarlige for, at dette produkt, som denne deklaration omhandler, er i overensstemmelse med standard eller andre normative dokumenter i følgebestemmelserne i direktiv 2004/108/EC.

Vi deklarerer härmed vårt fulla ansvar för att den produkt till vilken denna deklaration hänvisar är i överensstämmelse med standarddokument eller annat normativt dokument som framställs i direktiv 2004/108/EC.

Vi vakuillamme yksinomaaisella vastuullamme, että tuote, jota tämä ilmoitus koskee, noudattaa seuraavaa standardia tai muuta ohjeellista asiakirjaa, jotka noudattavat direktiivin 2004/108/EC säännöksiä.

Vi erklærer oss alene ansvarlige for at produktet som denne erklæringen gjelder for, er i overensstemmelse med følgende norm eller andre normgivende dokumenter som følger bestemmelsene i direktiv 2004/108/EC.

## Important safety instructions

- Read these instructions.
- Keep these instructions.
- Heed all warnings.
- Follow all instructions.
- Do not use this apparatus near water.
- Clean only with dry cloth.
- Do not block any ventilation openings. Install in accordance with the manufacturer's instructions.
- Do not install near any heat sources such as radiators, heat registers, stoves, or other apparatus (including amplifiers) that produce heat.
- Only use attachments/accessories specified by the manufacturer.
- Use only the cart, stand, tripod, bracket, or table specified by the manufacturer, or sold with the apparatus. When a cart is used, use caution when moving the cart/apparatus combination to avoid injury from tip-over.
- Unplug this apparatus during lightning storms or when unused for long periods of time.
- Refer all servicing to qualified service personnel. Servicing is required when the apparatus has been damaged in any way, such as power-supply cord or plug is damaged, liquid has been spilled or objects have fallen into the apparatus, the apparatus has been exposed to rain or moisture, does not operate normally, or has been dropped.

## Main functions

- H.264 and JPEG triple encoding**
  - A total of 3 outputs, comprising of 2 H.264 outputs and 1 JPEG output, can be provided.
- Power over Ethernet function**
  - When connecting with a PoE (Power over Ethernet) device, power will be supplied by simply connecting a LAN cable. (IEEE802.3af compliant)
- Adaptive darkness correction mode**
  - Corrects the blacked-out parts of dark areas of objects that have different illumination intensities.
- Panning/tilting function and preset position function**
  - A single camera provides wide area monitoring.
- Interactive communication with audio**
  - By using the audio output connector and the microphone in connector, receiving audio from the cameras on a PC and transmitting audio from the PC to the cameras is available.
- SDHC/SD memory card slot equipped**
  - It is possible to save H.264 videos and JPEG images on the SDHC/SD memory card manually at an alarm occurrence, during the period of the schedule, or on a web browser. It is also possible to save JPEG images at a network failure occurrence. (Download is possible.)

## Standard accessories

Confirm the following items are included in the camera's packaging.

Main Unit (1 pc.)	Flexible Stand (1 pc.)	Screw A (1 pc.)	Screw B (4 pcs.)
Washer S (1 pc.)	Washer L (1 pc.)	Safety Wire (1 pc.)	SD Card Cover (1 pc.)
Power cable plug (1 pc.)	Installation Guide (this document) ..... (1 pc.)	Warranty card (P model) ..... (1 pc.)	CD-ROM* ..... (1 pc.)
	Code label*2 ..... (1 pc.)		

\*1 The CD-ROM contains the operating instructions and different kinds of tool software programs.
\*2 This label may be required for network management. The network administrator shall retain the code label.

## Precautions for Installation

Panasonic assumes no responsibility for injuries or property damage resulting from failures arising out of improper installation or operation inconsistent with this documentation.

**This camera is designed to be used indoors.**

This camera is not operable outdoors.

Do not expose this camera to direct sunlight for hours and do not install the product near a heater or an air conditioner. Otherwise, it may cause deformation, discoloration and malfunction. Keep this camera away from water and moisture.

**Do not place this product in the following places:**

- Locations where it may get wet from rain or water splash
- Locations where a chemical agent is used such as a swimming pool
- Locations subject to humidity, dust, steam and oil smoke
- Locations that have a specific environment that is subject to an inflammable atmosphere or solvents
- Locations where a radiation, an X-ray, a strong radio wave or a strong magnetic field is generated
- Locations where corrosive gas is produced, Locations where it may be damaged by briny air such as seashores
- Locations where the temperature is not within the specified range (0°to +40° [32°to +104°F]).
- Locations subject to vibrations (This product is not designed for on-vehicle use.)
- Locations subject to condensation as the result of severe changes in temperature

**Be sure to remove this product if it is not in use.**

**Before installation**

- When this camera is mounted on a wooden ceiling or a wall, use the wood screws (accessory, Screw B). Screws to be used for other materials are not provided. Prepare the screws according to the material, structure, strength and other factors of the mounting area and the total weight of objects to be mounted.

- Ensure that the mounting surface, anchor and screws are sufficiently strong.
- Do not mount this product on a plaster board or a wooden section because they are too weak. If this product is unavoidably mounted on such a section, the section shall be sufficiently reinforced.

**Design and engineer the power supply system to turn on/off the power of this product.**

The product has no power switch. When installing the product, use a power supply device equipped with the ON-OFF switch for servicing.

**About the network connection**

When connecting to a network using the network cable of this product, observe the following. When wiring for the network, design and engineer not to be affected by thunder.

**Screw tightening**

- The screws and bolts must be tightened with an appropriate tightening torque according to the material and strength of the installation area.
- Do not use an impact driver. Use of an impact driver may damage the screws or cause tightening excessively.
- When a screw is tightened, make the screw at a right angle to the surface. After tightening the screws or bolts, perform visual check to ensure tightening is enough and there is no backlash.

**Procure fixing screws separately.**

The screws that secure this product are not supplied. Prepare them according to the material and strength of the area where the product is to be installed.

Required pull-out capacity of a single screw/bolt is 294 N {66.09 lbf} or more.

**14 prevention measures**

When the external safety wire is connected, select a connection point resulting in that nothing will hit people after the stand is damaged.

**Do not remove or loosen the internal camera screws.**

Do not loosen the internal camera screws. Otherwise, water exposure may cause damage or malfunction of camera, or camera dropping may result in injury.

**Radio disturbance**

When this product is used near TV/radio antenna, strong electric field or magnetic field (near a motor, a transformer or a power line), images may be distorted and noise sound may be produced.

**PoE (Power over Ethernet)**

Use a PoE hub/device that is compliant with IEEE802.3af standard.

**Router**

When connecting this product to the internet, use a broadband router with the port forwarding function (NAT, IP masquerade). Refer to the Operating Instructions (included in the CD-ROM) for further information about the port forwarding function.

**Time & date setting**

It is necessary to set the time & date before putting this product into operation. Refer to the Operating Instructions on the provided CD-ROM for descriptions of how to perform the settings.

## Troubleshooting

**Before asking for repairs, check the symptoms with the following table.**

Contact your dealer if a problem cannot be solved even after checking and trying the solution in the table or a problem is not described below.

Symptom	Cause/solution
Power is not turned on.	<ul style="list-style-type: none"><li>Are the PoE device and the network cable of the camera connected using a LAN cable? <ul style="list-style-type: none"><li>→ Check whether the connection is appropriately established.</li></ul></li> <li>Depending on the PoE device, the power supply will stop when the demanded power exceeds its total power limit for all PoE ports. <ul style="list-style-type: none"><li>→ Refer to the operating instructions of the PoE device in use.</li></ul></li></ul>

### Option

**You will need the following additional items to install and configure the camera.**

**[Locally procured]**

- PoE device (When supplying the power using the PoE device)
- A PC (see the system requirements in the Important Information document)
- router
- A LAN cable (CAT-5 straight cable)
- AC Adaptor (1 pc.)
- \*FOR UL LISTED MODEL(S), ONLY CONNECT 12 V DC CLASS 2 POWER SUPPLY.

## About the user manuals

There are 2 sets of operating instructions for the WV-ST165, WV-ST162 (P model), WV-ST165E, WV-ST162E (E model) as follows.

- Installation Guide: Explains how to install and connect devices, as well as how to connect and configure the network.
- Operating Instructions (included in the CD-ROM): Explains how to perform the settings and how to operate this camera.

Adobe® Reader® is required to read these operating instructions on the provided CD-ROM. When the Adobe® Reader® is not installed on the PC, download the latest Adobe Reader from the Adobe web site and install it.
\*WV-ST165, WV-ST162\* or \*ST165, ST162\* shown in the instructions and illustrations used in these operating instructions indicates the WV-ST165, WV-ST162, WV-ST165E, WV-ST162E. The screens used in these operating instructions show the cases of P models.

## Limitation of liability

THIS PUBLICATION IS PROVIDED "AS IS" WITHOUT WARRANTY OF ANY KIND, EITHER EXPRESS OR IMPLIED, INCLUDING BUT NOT LIMITED TO, THE IMPLIED WARRANTIES OF MERCHANTABILITY, FITNESS FOR ANY PARTICULAR PURPOSE, OR NON-INFRINGEMENT OF THE THIRD PARTY'S RIGHT.

THIS PUBLICATION COULD INCLUDE TECHNICAL INACCURACIES OR TYPOGRAPHICAL ERRORS. CHANGES ARE ADDED TO THE INFORMATION HEREIN, AT ANY TIME, FOR THE IMPROVEMENTS OF THIS PUBLICATION AND/OR THE CORRESPONDING PRODUCT (S).

## Disclaimer of warranty

IN NO EVENT SHALL Panasonic System Networks Co., Ltd. BE LIABLE TO ANY PARTY OR ANY PERSON, EXCEPT FOR REPLACEMENT OR REASONABLE MAINTENANCE OF THE PRODUCT, FOR THE CASES, INCLUDING BUT NOT LIMITED TO BELOW.
(1) ANY DAMAGE AND LOSS, INCLUDING WITHOUT LIMITATION, DIRECT OR INDIRECT, SPECIAL, CONSEQUENTIAL OR EXEMPLARY, ARISING OUT OF OR RELATING TO THE PRODUCT;
(2) PERSONAL INJURY OR ANY DAMAGE CAUSED BY INAPPROPRIATE USE OR NEGLIGENT OPERATION OF THE USER;

- ALL MALFUNCTIONS OR TROUBLES FROM UNAUTHORIZED DISASSEMBLY, REPAIR OR MODIFICATION OF THE PRODUCT BY THE USER, REGARDLESS OF THE CAUSE OF THE MALFUNCTION OR TROUBLE;
- INCONVENIENCE OR ANY LOSS ARISING WHEN IMAGES ARE NOT DISPLAYED, DUE TO ANY REASON OR CAUSE INCLUDING ANY FAILURE OR PROBLEM OF THE PRODUCT;
- ANY PROBLEM, CONSEQUENTIAL INCONVENIENCE, OR LOSS OR DAMAGE, ARISING OUT OF THE SYSTEM COMBINED BY THE DEVICES OF THIRD PARTY;
- ANY CLAIM OR ACTION FOR DAMAGES, BROUGHT BY ANY PERSON OR ORGANIZATION BEING A PHOTOGENIC SUBJECT, DUE TO VIOLATION OF PRIVACY WITH THE RESULT OF THAT SURVEILLANCE-CAMERA'S PICTURE, INCLUDING SAVED DATA, FOR SOME REASON, BECOMES PUBLIC OR IS USED FOR ANY PURPOSE;
- LOSS OF REGISTERED DATA CAUSED BY ANY FAILURE.

## System requirements for a PC

CPU: Intel® Core™ 2 Duo 2.4 GHz or faster recommended
Memory: 512 MB or more (A minimum of 1 GB memory is required when using Microsoft® Windows® 7 or Microsoft® Windows Vista®.)

Network interface: 10BASE-T/100BASE-TX 1 port

Monitor: Image capture size: 1024 x768 pixels or more

Color: 24-bit True color or better

OS: Microsoft® Windows® 7

Microsoft® Windows Vista®

Microsoft® Windows® XP SP3

Windows® Internet Explorer® 9.0 (32-bit)

Windows® Internet Explorer® 8.0 (32-bit)

Windows® Internet Explorer® 7.0 (32-bit)

Microsoft® Internet Explorer® 6.0 SP3

Others: CD-ROM drive

(It is necessary to read the operating instructions and use the software on the provided CD-ROM.)

DirectX® 9.0c or later

Adobe® Reader®

(It is necessary to view PDF file on the provided CD-ROM.)

<b>IMPORTANT</b>
<ul style="list-style-type: none"><li>When using a PC that does not meet the above requirements, displaying of images may become slower or the web browser may become inoperable.</li> <li>Microsoft Windows 7 Starter, Microsoft Windows Vista Starter and Microsoft Windows XP Professional 64-bit Edition are not supported.</li> <li>When using IPv6 for communication, use Microsoft Windows7 or Microsoft Windows Vista.</li></ul>
<b>Note</b>
<ul style="list-style-type: none"><li>Refer to "Notes on Windows 7/Internet Explorer® versions" (included in the CD-ROM) for further information about system requirements for a PC and precautions when using Microsoft Windows 7, Microsoft Windows Vista or Internet Explorer.</li> <li>If using Microsoft Windows XP, screen tearing* may occur when the shooting scene drastically changes (for example, while shooting fast-moving subjects) due to the GDl restrictions of the OS. A phenomenon in which portions of the screen are displayed out of alignment.</li> <li>For information on the operation verification of the supported operating systems and web browsers, refer to our website at http://panasonic.net/psp/security/support/indx.html.</li></ul>

## Specifications

<b>● Basic</b>	
Power source:	PoE (IEEE802.3af compliant), 12 V DC
Power consumption:	PoE: 130 mA (Class 2 device), 12 V DC: 430 mA
Ambient operating temperature:	0 °C to +40 °C (32 °F to 104 °F)
Ambient operating humidity:	Less than 90 % (no condensation)
Monitor output:	VBS: 1.0 V (p-p)/75 Ω, composite (BNC), ø3.5 mm mini jack
EXT I/O terminal cable:	ALARM IN 1, ALARM IN 2/ ALARM OUT, ALARM IN 3/ AUX OUT, GND, 12 V DC
Microphone/Line input:	ø3.5 mm monaural mini jack Input impedance: Approx. 2.2 kΩ Applicable microphone: Plug-in power type Supply voltage: 3.3 V ±0.5 V Input level: Approx. -10 dBV
For line input:	Input level: Approx. -10 dBV
Audio output:	ø3.5 mm stereo mini jack (monaural output) Output impedance: Approx. 560 Ω Line level
Dimensions:	100 mm (W) x 100 mm (H) x 74 mm (D) [3-47/50 inches (W) x 3-47/50 inches (H) x 2-23/25 inches (D)] (excluding projection)
Mass:	Main body: 345 g (0.76 lbs)
Finish:	Main body : PC/ABS resin, sail white Dome section: Clear polycarbonate resin
<b>● Camera</b>	
Image sensor:	1/4 type MOS image sensor
Effective pixels:	Approx. 1.3 megapixels
Scanning area:	3.52 mm (H) x 2.64 mm (V) [7/50 inches (H) x 1/10 inches (V)]
Scanning system:	Progressive
Minimum illumination:	Color: 0.6 lx [0.06 footcandle] (F2.2, Auto slow shutter: Off (1/30 s), Gain: On (High)) 0.039 lx (0.0038 footcandle) (F2.2, Auto slow shutter: Max. 16/30 s, Gain: On (High))* BW: 0.5 lx [0.05 footcandle] (F2.2, Auto slow shutter: Off (1/30 s), Gain: On (High)) 0.031 lx (0.0031 footcandle) (F2.2, Auto slow shutter: Max. 16/30 s, Gain: On (High))* * Converted value
Wide dynamic range:	On/Off
Face WDR:	On/Off
Gain (AGC):	On (Low)/ On (Mid)/ On (High)/ Off
Adaptive black stretch:	On/Off
Light control mode setting:	Indoor scene [50Hz/60Hz]/ELC
ELC (Maximum exposure time):	ELC(1/30 s), ELC(3/100 s), ELC(3/120 s), ELC(2/100 s), ELC(2/120 s), ELC(1/100 s), ELC(1/120 s), ELC(1/250 s), ELC(1/500 s), ELC(1/1000 s), ELC(1/2000 s), ELC(1/4000 s), ELC(1/10000 s)
Auto slow shutter:	Off (1/30 s), Max. 2/30s, Max. 4/30s, Max. 6/30s, Max. 10/30s, Max. 16/30s
Day & Night (electrical):	Off/Auto
White balance:	ATW1/ ATW2/ AWC
Digital noise reduction:	High/Low
Video analytics	On/Off (with the XML notification setting)
Face detection:	On/Off
Privacy zone:	On/Off (up to 2 zones available)
Camera title on screen:	Up to 20 characters (alphanumeric characters, marks), On/Off
Video motion detection (VMD alarm):	On/Off, (available at each preset)
<b>● Lens</b>	
Zoom ratio:	Extra zoom: 2x (under VGA resolution)
Digital (electronic) zoom:	8x (Max 16x combined with Extra Optical Zoom under VGA)
Focal length:	1.95 mm
Maximum aperture ratio:	1: 2.2
Focus range:	∞ - 0.5 m
Angular field of view:	Horizontal: 85°, Vertical: 68°
<b>● Panning/tilting platform</b>	
Panning range:	-47.5° - +47.5°
Panning speed:	Manual: Approx. 5 °/s - 80 °/s, Preset: Up to approx. 80 °/s
Tilting range:	-45° to +10°
Tilting speed:	Manual: Approx. 5 °/s - 80 °/s, Preset: Up to approx. 80 °/s
Number of the preset positions:	64
Map shot:	Preset map-shot
Self return:	10 s/ 20 s/ 30 s/ 1 min/ 2 min/ 3 min/ 5 min/ 10 min/ 20 min/ 30 min/ 60 min

### Trademarks and registered trademarks

- Adobe, the Adobe logo, and Reader are either registered trademarks or trademarks of Adobe Systems Incorporated in the United States and/or other countries.
- Microsoft, Windows, Windows Vista, Internet Explorer, ActiveX, and DirectX are either registered trademarks or trademarks of Microsoft Corporation in the United States and/or other countries.
- Microsoft product screen shot(s) reprinted with permission from Microsoft Corporation.
- Intel and Intel Core are trademarks or registered trademarks of Intel Corporation in the United States and other countries.
- iPad, iPhone, and iPod touch are registered trademarks of Apple Inc., registered in the U.S. and other countries.
- All other trademarks identified herein are the property of their respective owners.

## Copyright

Distributing, copying, disassembling, reverse compiling and reverse engineering of the software provided with this product are all expressly prohibited. In addition, exporting any software provided with this product violating export laws is prohibited.

## Network security

As you will use this unit connected to a network, your attention is called to the following security risks.

- Leakage or theft of information through this unit
- Use of this unit for illegal operations by persons with malicious intent
- Interference with or stoppage of this unit by persons with malicious intent

It is your responsibility to take precautions such as those described below to protect yourself against the above network security risks.

- Turn the power off immediately and contact qualified service personnel for service.
- If this unit is connected to a network that includes PCs, make sure that the system is not infected by computer viruses or other malicious entities (using a regularly updated anti-virus program, anti-spyware program, etc.).
- Protect your network against unauthorized access by restricting users to those who log in with an authorized user name and password.
- Apply measures such as user authentication to protect your network against leakage or theft of information, including image data, authentication information (user names and passwords), alarm mail information, FTP server information and DDNS server information.
- After the unit is accessed by the administrator, make sure to close the browser.
- Change the administrator password periodically.
- Do not install the camera in locations where the camera or the cables can be destroyed or damaged by persons with malicious intent.

## Precautions

- ⚠ WARNING**
- Refer installation work to the dealer.**
    - Installation work requires technique and experiences. Failure to observe this may cause fire, electric shock, injury, or damage to the product.
      - Be sure to consult the dealer.
  - Stop the operation immediately when something is wrong with this product.**
    - When smoke goes up from the product, the smell of smoke comes from the product, or the exterior of the product has deteriorated, continued use will cause a fire or fall of the product resulting in injury, or damage to the product.
      - Turn the power off immediately and contact qualified service personnel for service.
  - Select an installation area that can support the total weight.**
    - Selecting an inappropriate installation surface may cause this product to fall down or topple over, resulting in injury.
      - Installation work shall be started after sufficient reinforcement.
  - Periodic inspections shall be conducted.**
    - Loosening of mounting screws or bolts may cause a fall of the product resulting in injury or accidents.
      - Consult the dealer for the inspections.
  - The screws and bolts must be tightened to the specified torque.**
    - Failure to observe this may cause a drop resulting in injury or accidents.
  - Do not install this product in locations subject to vibration.**
    - Loosening of mounting screws or bolts may cause a fall of the product resulting in injury.
  - The measures of protection against a fall of this product shall be taken.**
    - Failure to observe this may cause a drop resulting in injury or accidents. Be sure to install the safety wire.
  - Install this product in a location high enough to avoid people and objects from bumping the product.**
    - Failure to observe this may cause a drop resulting in injury or accidents.
  - Turn the power off when do wiring of this product.**
    - Failure to observe this may cause electric shock. In addition, short circuit or wrong wiring may cause fire.
  - Do not attempt to disassemble or modify this product.**
    - Failure to observe this may cause fire or electric shock. Consult the dealer for the repair or inspections.
  - Do not insert any foreign objects.**
    - This could permanently damage this product. Turn the power off immediately and contact qualified service personnel for service.
  - Do not use this product in an inflammable atmosphere.**
    - Failure to observe this may cause an explosion resulting in injury.
  - Avoid installing this product in the locations where salt damage occurs or corrosive gas is produced.**
    - Otherwise, the mounting portions will deteriorate and accidents such as a fall of the product may occur.
  - Do not strike or give a strong shock to this product.**
    - Failure to observe this may cause fire or injury.
  - Do not rub the edges of metal parts with your hand.**
    - Failure to observe this may cause injury.
  - Do not touch this product or the connected cables during thunder. (even in the process of work)**
    - Failure to observe this may cause electric shock.
  - Keep SDHC/SD memory cards (option) away from infants and children.**
    - Otherwise, they may swallow the cards by mistake.
      - In this case, consult a doctor immediately.

### ⚠ CAUTION

- Turn the power off when cleaning this product.**
  - Failure to observe this may cause injury.

## Precautions for use

**This system is designed to be used indoors. This product is not operable outdoors.**

**This product has no power switch.**



# 1 Check the installing place

## Determining the mounting position

**IMPORTANT**  
Do not mount this product on a plaster board or a wooden section because they are too weak. If this product is unavoidably mounted on such a section, the section shall be sufficiently reinforced.

**IMPORTANT**  
Do not install this on locations subject to vibrations.

**IMPORTANT**  
Do not install near any heat sources.

**IMPORTANT**  
Do not install this by products that generates a strong radio wave or a strong magnetic field.

**IMPORTANT**  
Do not install on locations subject to humidity and oil smoke.

## Determining how to wire the cable

It is necessary to make a hole in the ceiling or wall to pass the cables through. Make a hole 25 mm (31/32") in diameter.

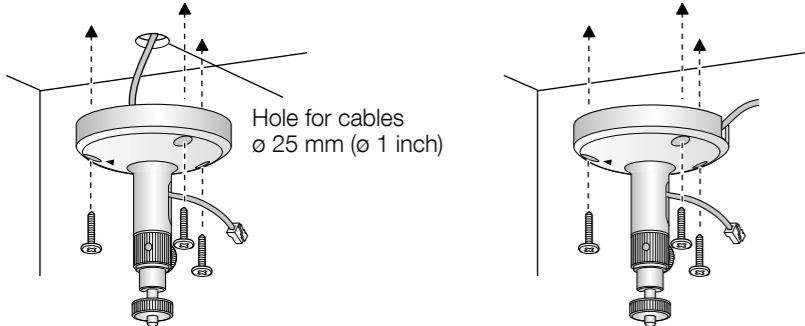

## Determining the length of the cable

Confirm the distance from the camera's installation position to the computer and then prepare the necessary length of LAN cable (locally procured).

## Determining how to mount the camera

**Installing the camera on the ceiling or wall**  
Make sure the flexible stand is firmly mounted on a beam of wood (25 mm [1 inch] and greater) etc. When there is no beam, apply a board on the other side of the ceiling or wall to make sure the camera does not drop.

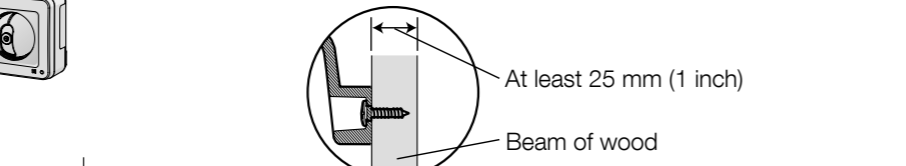

**When mounting on a mortar or concrete surface**  
Prepare anchors for 4 mm (3/16 inch) diameter screws for mounting. Mortar ceilings or walls break easily when drilling. Be careful of pieces of mortar which may become loose and fall.

1. Place the flexible stand on the ceiling or wall where you plan to mount the flexible stand and mark the points where you are going to make holes.
2. Make holes with an electric drill. Insert anchors (locally procured) into the holes and push them inside the holes with a hammer.
3. Mount the flexible stand using the screws.

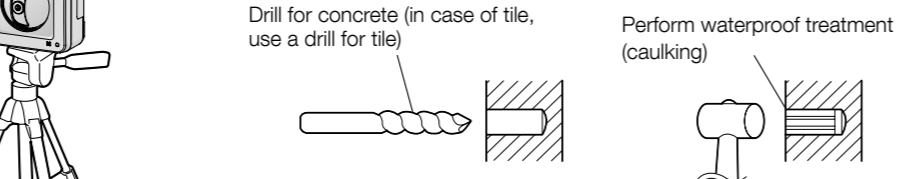

**Tripod Mount**  
It is also possible to mount the camera on a standard tripod stand (locally procured).

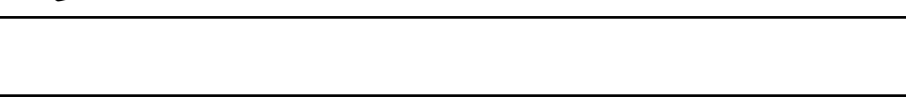

# 2 Major operating controls

## <Front view>

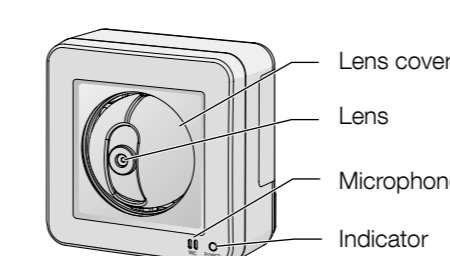

## <Side and bottom view>

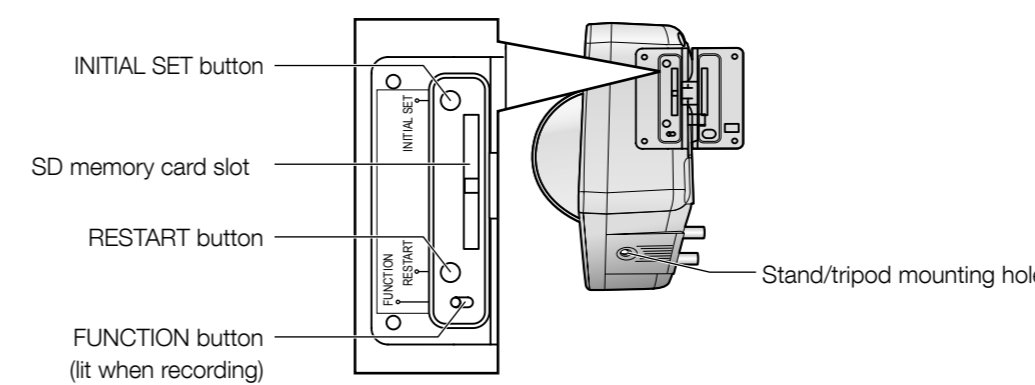

## <Rear view>

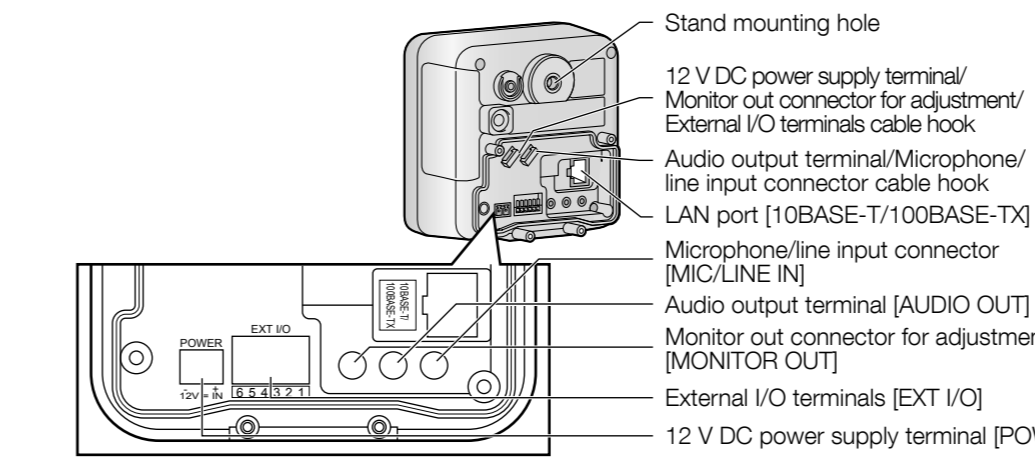

## External I/O terminals

Pin	Function
6	DC power output • Power output voltage 10.5 V - 13 V • Power output current 100 mA
5	GND
4	GND
3	EXT I/O terminal 3 (ALARM IN 3/ AUX OUT)
2	EXT I/O terminal 2 (ALARM IN 2/ ALARM OUT)
1	EXT I/O terminal 1 (ALARM IN 1)

## About the [INITIAL SET] button

After turning off the power of the camera, turn on the power of the camera while holding down this button, and wait for around 5 seconds or more without releasing this button. Wait around 3 minute after releasing the button. The camera will start up and the settings including the network settings will be initialized. Before initializing the settings, it is recommended to write down the settings in advance. The initialization will be complete when the live indicator stops blinking orange and lights off. Note that the preset position settings and the CRT key (SSL encryption key) used for the HTTPS protocol will not be initialized.

## IMPORTANT

- Do not turn off the power of the camera during the process of initialization. Otherwise, it may fail to initialize and may cause malfunction.

## About the [RESTART] button

When the camera is on, you can also restart the camera by pressing the RESTART button. Press and hold the RESTART button for about one second with a pointed object. Restarting is completed when the camera's pan/tilt performs its initial movement.

# 3 Connections

## When connecting the camera using PoE (Power over Ethernet)

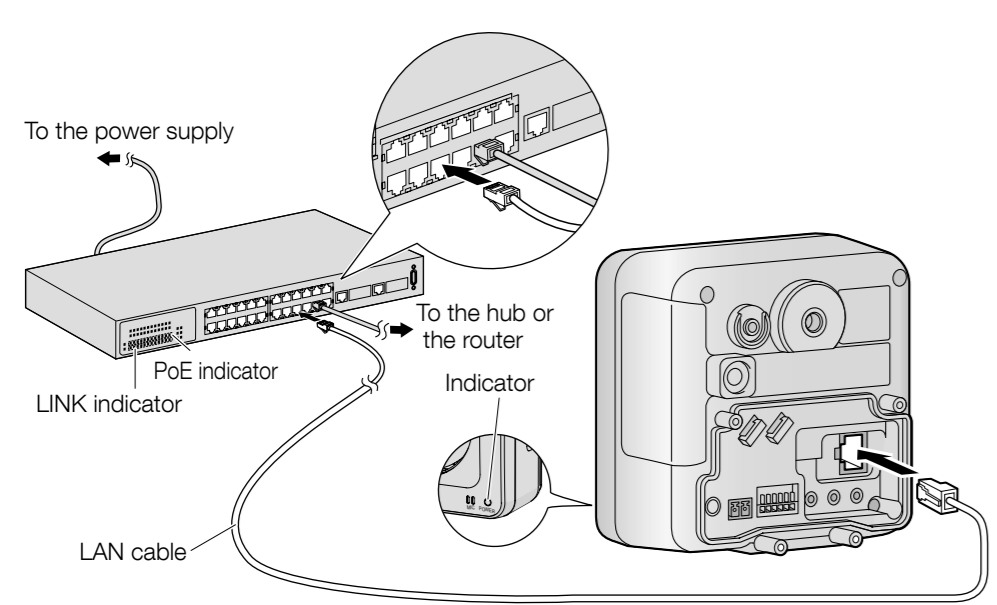

**Note**

- If the indicator does not turn green, see "Troubleshooting" in the Operating Instructions on the provided CD-ROM.
- Refer to the operating instructions of the product in use about the operations of the PoE device.

**IMPORTANT**

- Use a 4-pair UTP/STP cable.
- Make sure that the PoE device in use is compliant with IEEE802.3af standard.
- For information on recommended PoE devices, refer to our website at (<http://panasonic.net/pss/security/support/info.html>).

## When connecting the camera using 12 V DC power supply

**Caution:**  
FOR UL LISTED MODEL(S), ONLY CONNECT 12 V DC CLASS 2 POWER SUPPLY.

1. Loosen the screw of the power cord plug (accessory).
2. Connect the cable of the 12 V DC power supply\* to the power cord plug. Strip 3 mm to 7 mm (1/8 inches to 9/32 inches) from the end of the wire, and twist the stripped part of the wire sufficiently to avoid short circuit. Specification of cable (wire): 16 AWG - 24 AWG, Single core, twisted. Check whether the stripped part of the wire is not exposed and is securely connected.
3. Tighten the screw of the power cord plug.
4. Connect the power cord plug to the 12 V DC power supply terminal on the rear of the camera.

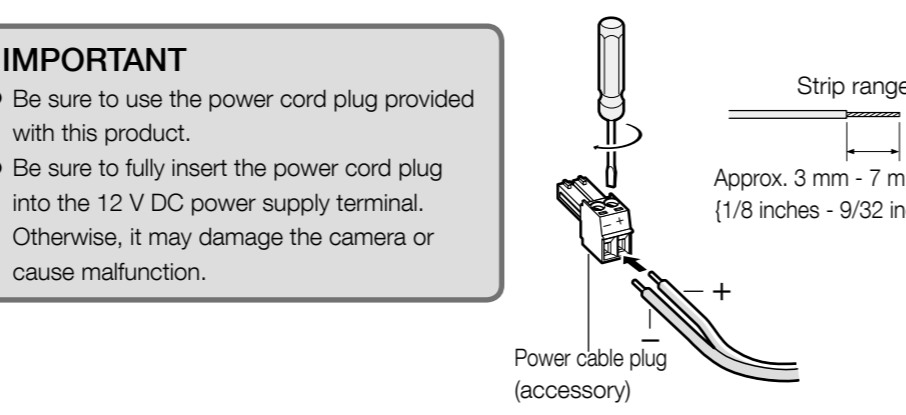

**IMPORTANT**

- Be sure to use the power cord plug provided with this product.
- Be sure to fully insert the power cord plug into the 12 V DC power supply terminal. Otherwise, it may damage the camera or cause malfunction.

**External I/O terminals**  
Connect external devices to the EXT I/O terminal. When connecting an external device, remove 9 mm - 10 mm (11/32 inches - 13/32 inches) of the outer jacket of the cable and twist the cable core to prevent the short circuit first.  
Specification of cable (wire): 22 AWG - 28 AWG, Single core, twisted

## Remove a SD memory card

1. Close the slide cover on the side of the camera.
2. Press the FUNCTION button.  
When the FUNCTION button is pressed, recording stops and the green light turns off. Confirm that the FUNCTION button green light has turned off before proceeding to step 3.
3. Push the card slightly to eject it, then remove the card.
4. Close the cover.

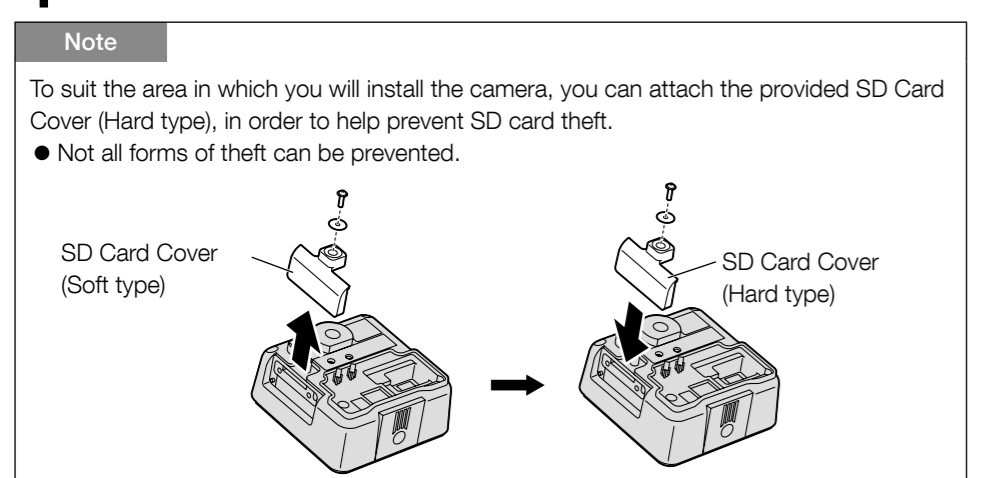

**IMPORTANT**

- Make sure that SD memory card recording has stopped and that the card is not being accessed before removing the card. (The FUNCTION button will light while images are being recorded to the card.) We recommend pressing the FUNCTION button to stop SD memory card recording before ejecting the card.
- If the SD memory card is removed while it is being recorded to or accessed, the card may become unreadable and may need to be formatted (i.e., erased) again before use.

# 4 Configure the settings of the camera

## Configuring the camera so that it can be accessed from a PC

If you are using firewall software on your PC, the Setup Program may not be able to find any cameras on your network. Configure the setting of the camera after temporarily invalidating the firewall software.

1. Insert the provided CD-ROM into the CD-ROM drive of your PC
  - The License Agreement will be displayed. Read the Agreement and choose "I accept the term in the license agreement", and click [OK].
  - The launcher window will be displayed. If the launcher window is not displayed, double click the "CDLauncher.exe" file on the CD-ROM.



2. Click the [Run] button next to [IP Setting Software].  
\*Panasonic IP Setting Software\* page will be displayed. Click the [Network Settings] button after selecting the MAC address/IP address of the camera to be configured.
3. Select the camera you want to configure, and click [Access Camera].

**Note**

- When cameras are displayed in [IP Setting Software] screen, click the camera with same MAC address as the MAC address printed on the camera that you want to configure.

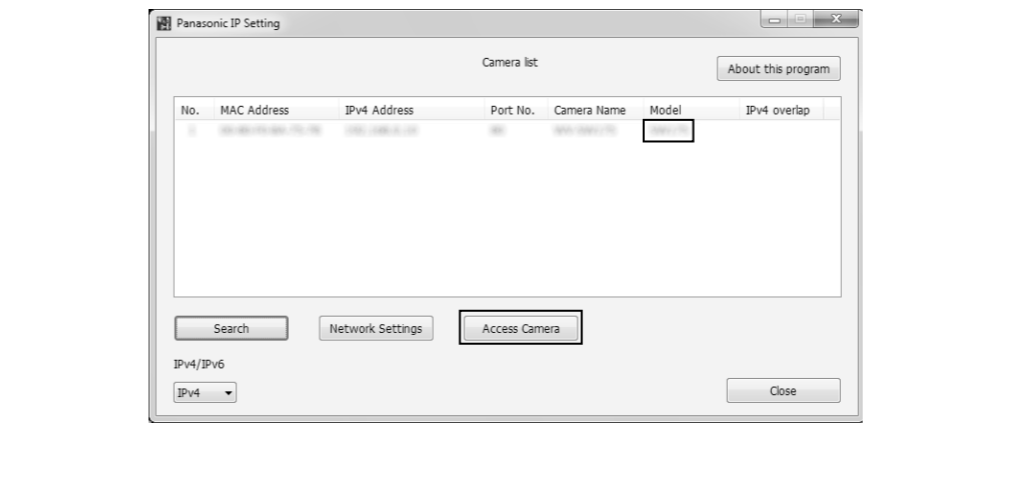

## Monitor out connector for adjustment

Connect a monaural mini plug (6.35 mm) (only for checking if images are displayed on the monitor).

**IMPORTANT**

- Recommended plug: L type
- The monitor out connector for adjustment is provided only for checking the adjustment of the angular field of view on the video monitor when installing the camera or when servicing. It is not provided for recording/monitoring use.
- Black bands may appear at the top and bottom or right and left of the screen. (That does not affect the adjustment because the angular field of view is not changed.)

## Insert a SD memory card

1. Open the cover on the side of the camera.
2. Insert the SD memory card with the label facing the rear of the camera and the pins facing the front of the camera. Gently push the card with your finger until it clicks.
3. Close the cover.

**Note**

- If the camera's indicator turns red, remove the SD memory card and confirm that the card is not write-protected. If the indicator is still red, the card must be formatted before it can be used.

# 5 Mounting the Camera

Adjust the camera to a suitable position/direction while confirming the images actually displayed on the computer screen.

## Wiring without making a hole for a cable in the ceiling or wall

1. Place the flexible stand (accessory) on the ceiling or wall, and determine the mounting position of the stand.  
Make sure the flexible stand is firmly mounted on a beam of wood (25 mm [1 inch] and greater) etc. When there is no beam, apply a board on the other side of the ceiling or wall to make sure the camera does not drop.
2. Secure the safety wire (accessory) to the camera using screw A (accessory) and washer S (accessory).
3. Remove the tab on the flexible stand.
4. Pass the cables through the notch.  
When there are many cables to pass through the notch, pass through the larger cables first.

**IMPORTANT**  
If the cables cannot be passed through the notch, wrap the cables to the stand shaft using tape (locally procured) or other materials.

## 5 Mount the flexible stand firmly to the ceiling or wall with screw B (accessory).

When mounting the flexible stand to the wall, position the flexible stand so that the '▲' marker is facing upward.

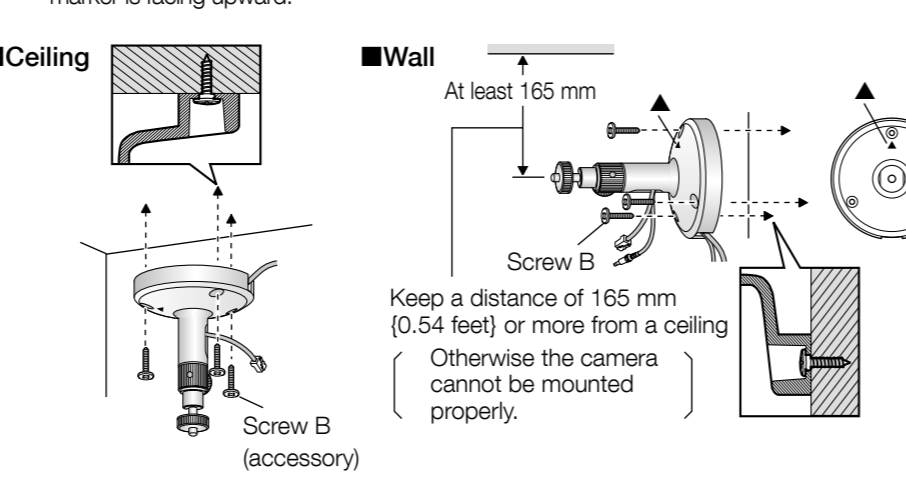

## 6 Attach the camera by screwing the threaded mount into the stand mounting hole.

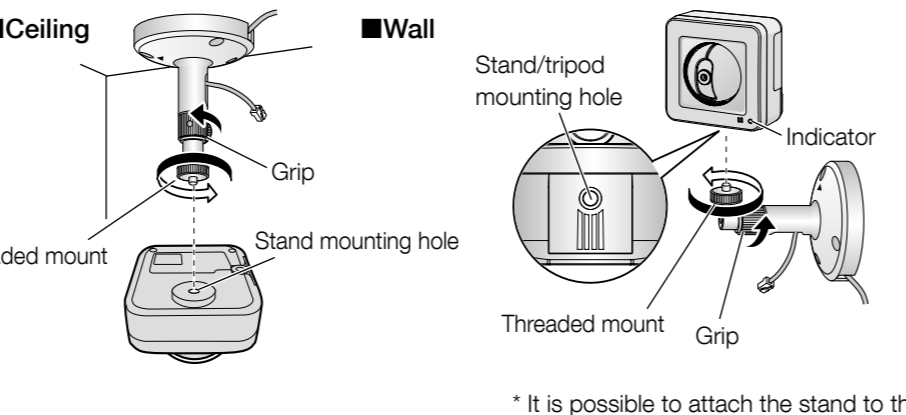

\* It is possible to attach the stand to the stand mounting hole, the rear of the camera.

## 7 Pass the cables through the connector cover, and then connect all necessary cables (AC adaptor, LAN, audio/video, etc.). Refer to "Connections".

**IMPORTANT**  
When installing the camera, hook the cord of the AC adaptor (locally procured) and the cables for the external speaker/external sensor/mic/video, etc. around the hooks when making connections.

## 8 Adjust the camera position and tighten the flexible stand grip and the tightening screw firmly.

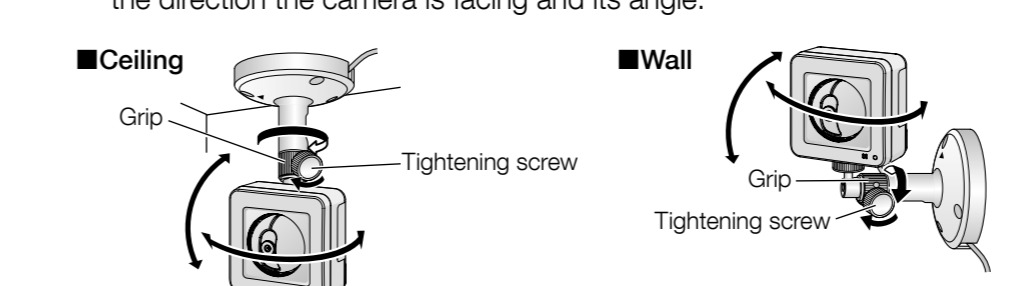

## 9 Adjust the length of the safety wire when it is taut, and secure it to the ceiling or wall using screw B (accessory) and washer L (accessory).

Attach the safety wire in a position so that if the camera were to become detached, it would not fall on nearby people.

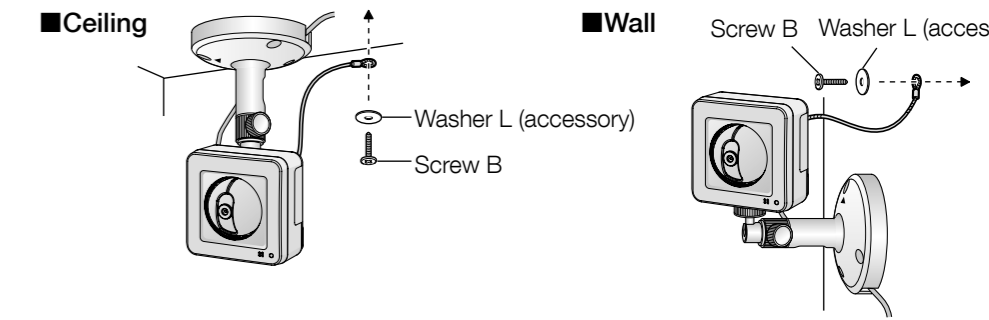

## Wiring through a hole made in the ceiling or wall

Make a hole for cables in the ceiling or wall. Secure the safety wire to the camera and pass the cables through the notch. Then follow steps 2, 4 to 9. It is not necessary to remove the tab on the flexible stand.

